

**MESON'S**

[Redacted]

[Redacted]

**M** EMO

M\_EMO



M\_emo recupera i valori della cucina in legno, aggiornando allo stesso tempo i contenuti tecnologici. E' evidente la centralità del legno, lavorato secondo una lunga e nobile tradizione ebanistica. La scelta dell'essenza di olmo conferisce ulteriore pregio al frontale e ai vari complementi, disponibili in sette diversi colori, frutto di un'attenta selezione. Le diverse colorazioni, pur garantendo una forte caratterizzazione cromatica, non tolgono al tatto la tipica matericità del legno. M\_emo ambisce ad unire tradizione ed innovazione, proponendo cucine senza tempo, che interpretano e superano mode e tendenze.

M\_emo recovers the values of the wooden kitchen, updating at the same time the technological content. The centrality of wood is evident, worked according to a long and noble tradition of woodworking. The choice of elm essence gives added value to the front and to the various complements, available in seven different colours, result of a careful selection. The different colours, while guaranteeing a strong colour characterization, do not relieve the typical materiality of the wood. M\_emo aims to combine tradition and innovation, offering timeless kitchens that interpret and overcome fashion and trends.

---

**M**\_EMO

# INDEX

---

---

C01	6
C02	30
C03	44
C04	62
C05	76
C06	92

---





Attrezzature metalliche e superfici in gres conferiscono un'identità professionale senza perdere calore e convivialità.

Metallic equipment and Gres surfaces give professional identity without losing warmth and conviviality









La composizione alterna zone dispensa ad aree tecniche destinate alla preparazione dei cibi. Non mancano gli elementi distintivi come le piattae, formate da listelli di legno sapientemente distanziati, in un gioco equilibrato di pieni e vuoti.

The composition alternates pantry areas to technical areas intended for the preparation of foods. There are also distinctive elements such as plate racks, formed by carefully spaced wooden strips, in a balanced interplay of solids and voids.





La particolare lavorazione dell'anta in Olmo Cenere genera nel telaio uno spazio per l'apertura; nel quale un profilo in alluminio finitura Brown sottolinea il punto di presa diventando un raffinato segno estetico e funzionale.



The particular workmanship of the door in Cenere Elm generates in the frame a space for the opening; in which a Brown finish aluminium profile emphasizes the grip point, becoming a refined aesthetic and functional sign.





Il piano di lavoro in Laminam Orobico Grigio Opaco integra il piano cottura, il lavello e diversi accessori. Nonostante le ampie superfici le varie funzioni ed attrezzature risultano facilmente raggiungibili.

The worktop in Laminam Orobico Grigio Matt integrates hob, sink and various accessories. Despite the large surfaces, the various functions and equipment are easily accessible.



Il lavello in pietra sporgente è un tipico elemento delle cucine in legno. La continuità del materiale ceramico tra piano di lavoro e lavello è possibile grazie ad innovative ed affidabili tecnologie che consentono il rivestimento del lavabo in acciaio e creano un blocco monomaterico.

The protruding stone sink is a typical element of wooden kitchens. The continuity of the ceramic material between worktop and sink is possible thanks to innovative and reliable technologies that enable the steel sink coating and create a monomateric block.









Strutture metalliche dividono e collegano gli ambienti, ridistribuiscono gli spazi, ottimizzando il rapporto tra contenitori e ripiani. La scaffalatura può essere equipaggiata di elettrodomestici, contenitori vetrina, ripiani e schienali divisorii, sempre distinguendosi per leggerezza e praticità.

Metal structures divide and connect environments, redistribute spaces, optimizing the relation between containers and shelves. The shelving can be equipped with appliances, display cabinets, dividing shelves and back panels, always distinguishing for lightness and practicality.









I pensili a giorno alleggeriscono la composizione pur mantenendo inalterata la capacità di contenere. Sono realizzati in Olmo Cenere con bordo laccato Brown in tinta con i telai vetrina e le strutture metalliche.

Open wall units lighten the composition while maintaining the capacity to contain. They are made of Cenere Elm with Brown lacquered edge matching the frames of display cabinets and of metal structures.









I volumi variano in profondità senza però interrompere la continuità delle finiture. In questo modo i contenitori a giorno diventano schienale mantenendo la finitura Olmo Naturale così come il piano di lavoro si erge sulla parete, rivestendola e proteggendola.

The volumes vary in depth without interrupting the continuity of finishes. In this way, the open containers become back panel, maintaining the Natural Elm finish as well as the worktop rises on the wall, covering and protecting it.









Il piano di lavoro in Ceramica, grazie alla sua particolare lavorazione, si stacca dalle basi creando un effetto di sospensione. Nei frontali in Olmo Naturale sono particolarmente apprezzabili le "fiamme" ad altezza variabile dell'impiallacciatura orizzontale.

The Ceramic worktop, thanks to its special workmanship, is detached from the base units creating a suspension effect. In Natural Elm fronts the "flames" of variable height in the horizontal veneer are particularly appreciable.

La colonna ad angolo in Olmo Lava, sfrutta al meglio lo spazio a disposizione, e grazie alla sua attrezzatura interna, il contenuto è facilmente accessibile.

The corner tall unit in Lava Elm makes the most of the available space and, thanks to its internal equipment, the content is easily accessible.





La fine lavorazione del telaio integra il vetro, disponibile in diverse finiture, caratterizzate da diversi gradi di trasparenza. La versione rappresentata è flutes acidato verniciato.

The fine workmanship of the frame integrates the glass, available in different finishes, characterized by different degrees of transparency. The illustrated version is painted etched flutes.









La generosa isola in Olmo Fumo si erge a protagonista assoluta in un contesto minimale. Tutte le funzioni sono integrate al sottile piano di lavoro in acciaio Inox, dando vita ad un piacevole contrasto tra tradizione e tecnologia.

The generous island in Fumo Elm stands out as the absolute protagonist in a minimal setting. All functions are integrated into the thin stainless steel worktop, creating a pleasant contrast between tradition and technology.









La tecnologia della lavorazione dell'acciaio presente sul piano di lavoro, sui fianchi in accosto, sul profilo del frontale e sullo zoccolo si contrappone al calore del legno che viene utilizzato anche nel rivestimento dei cassetti interni.

The steel processing technology on the worktop, on the side panels, on the front profile and on the plinth contrasts with the warmth of wood, which is also used in the coating of internal drawers.



Cambiano le funzioni ma non cambia il materiale. Preparazione, lavaggio e cottura sono saldati, integrati e "nascosti" in un'unica lastra di acciaio.

Functions changes but the material does not change.  
Preparation, washing and cooking are welded, integrated and "hidden" in a single steel plate.





Quando la capiente vasca non è in uso viene chiusa da un coperchio in acciaio che, una volta abbassato, rappresenta un ulteriore piano di lavoro.

When the large sink basin is not used, it is closed by a steel cover that, once lowered, represents a further worktop.





Una vasta gamma di accessori e separatori in Faggio tinto grigio organizza al meglio l'interno dei cassetti.

A wide range of accessories and separators in grey stained Beech organizes the interior of the drawers in the best way.

Le colonne laccate Brown integrano la parete collocandosi a filo della stessa anche grazie all'assenza di maniglie, garantita dall'apertura push-pull. La colonna vetro C\_scrigno, ospita una cassetiera a tre cassetti e ripiani in vetro.

Brown lacquered tall units integrate the wall by placing themselves flush with the wall also thanks to the absence of handles, guaranteed by the push-pull opening. C\_scrigno glass tall unit houses a three-drawer chest of drawers and glass shelves.









OLMO GESSO\_RAME  
LACCATO BROWN OPACO  
LAMINAM OSSIDO NERO



L'equilibrata alternanza tra bianchi e neri si esprime grazie ai frontali delle basi in Olmo Gesso e al piano di lavoro in Laminam Ossido Nero. Il bicolore si ripete negli elementi a giorno con bordi frontali in laccato Brown.

The balanced alternation between white and black is expressed thanks to the base unit fronts in Gesso Elm and the Laminam Ossido Nero worktop. The two-coloured game is repeated in the open elements with Brown lacquered front edges.









I blocchi lavaggio e cottura/aspirazione sono volutamente evidenziati, recuperando la memoria e il sapore delle cucine di un tempo.

The washing and cooking/aspiration blocks are deliberately highlighted, recovering the memory and the taste of the kitchens of the past.



Sviluppata su un'unica parete, questa composizione appaga ogni richiesta di funzionalità.

Developed on a single wall, this composition satisfies every demand for functionality.





La possibilità di rivestire il frontale del primo cestone, con lo stesso materiale del piano di lavoro, permette di rafforzare il concetto visivo del blocco lavello.

The possibility to coat the front of the first deep drawer with the same material as the worktop, allows to reinforce the visual concept of the sink block.





OLMO TABACCO\_TITANIO  
LACCATO BURRO LUCIDO  
LAMINAM BIANCO STATUARIO VENATO SOFT TOUCH

L'Olmo Tabacco, veste questa composizione a penisola esaltandone i volumi. Forme e materiali che si accostano e si fondono perfettamente fanno di questa cucina l'emblema dell'eleganza.

Tabacco Elm dresses this peninsular unit composition exalting its volumes. Shapes and materials that join together and perfectly blend, make this kitchen the emblem of elegance.









Le vetrine con anta telaio Brown e vetro trasparente completano e alleggeriscono la composizione. La luce verticale, incassata in prossimità dello schienale, illumina uniformemente l'interno, ed i ripiani in vetro ne favoriscono la diffusione.

The display cabinets with Brown framed door and transparent glass complete and lighten the composition. The vertical light, recessed in the proximity of the back panel, uniformly illuminates the interior, and the glass shelves favour its diffusion.







La particolare disposizione crea un luogo di condivisione tra la cucina e l'area living. Il rivestimento in Laminam Bianco Statuario Venato soft touch del top riveste la parete laterale su cui si collocano le vetrine donando eleganza e raffinatezza.

The particular arrangement creates a place of sharing between the kitchen and the living area. The coating of the worktop in Laminam Bianco Statuario Venato Soft Touch coats the side wall on which the display cabinets are placed, giving elegance and sophistication.





La colonna frigo con apertura automatizzata consente di avere frontali puliti in accosto con le colonne ad apertura push-pull. Inoltre la linearità dei frontali ne permette la perfetta integrazione all'interno dell'architettura.

The fridge tall unit with automated opening allows you to have clean fronts approached to the tall units with push-pull opening. Moreover, the linearity of the fronts allows the perfect integration within the architecture.







Equilibri ed accostamenti materici disegnano questa composizione che evoca la cucina tradizionale in legno.

Balances and material combinations draw this composition that evokes the traditional wooden kitchen.









La conformazione della cucina permette di rispettare quelle che sono le regole dell'ergonomia e l'aspetto di fruibilità della composizione stessa, mantenendo la giusta distanza e collocazione, tra il luogo di preparazione e cottura dei cibi e la zona dispensa.

The conformation of the kitchen allows to comply with the rules of ergonomics and the aspect of usability of the composition itself, maintaining the right distance and placement between the food preparation and cooking area and the pantry area.





La matericità dell'Olmo Naturale e della ceramica Laminam, Nero Greco Opaco, accompagnate da superfici laccate in Ardesia Lucido, disegnano una composizione senza tempo.

The materiality of Nature Elm and Laminam Ceramic, Nero Greco Matt, accompanied by Ardesia Gloss lacquered surfaces, draw a timeless composition.

Il lavello profondo e sagomato sul piano di lavoro, si appoggia e si incassa perfettamente sulle basi in Olmo Naturale.  
La profondità del blocco lavello, superiore a quella delle basi, evidenzia il confine tra i diversi volumi .

The deep and shaped sink on the worktop, leans and perfectly fits on the base units in Natural Elm.  
The depth of the sink block, higher than that of the base units, highlights the boundary between the different volumes.













# FINISHES

---

---

OLMO / ELM

PROFILO ANTA / DOOR PROFILE

LAMINAM / LAMINAM

CORIAN / CORIAN

---

OLMO  
ELM



Olmo  
Naturale

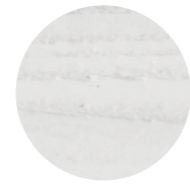

Olmo  
Gesso



Olmo  
Tabacco



Olmo  
Cenere



Olmo  
Fumo



Olmo  
Grigio

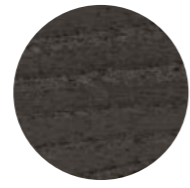

Olmo  
Lava

PROFILO ANTA  
DOOR PROFILE



Titanio

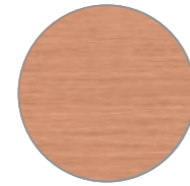

Rame



Bronzo



Brown

LAMINAM  
LAMINAM  
Collezione Lapis  
Lapis Collection



Pietra di Savoia  
Grigia  
Bocciardata

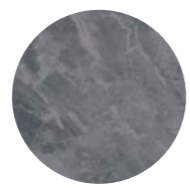

Orobico  
Grigio



Ossido  
Nero



Ossido  
Bruno

Collezione Ossido  
Ossido Collection

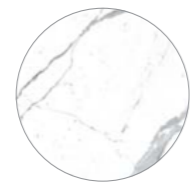

Bianco Statuario  
Venato  
Soft Touch

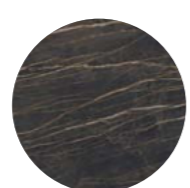

Noir Desir  
Opaco



Nero Greco  
Opaco

CORIAN  
CORIAN



Antartica



Dune Prima

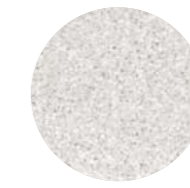

Silver Birch



Cocoa  
Prima

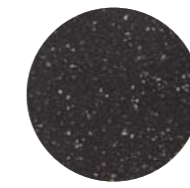

Gravel

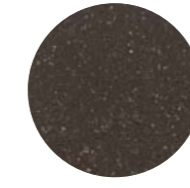

Cocoa  
Brown

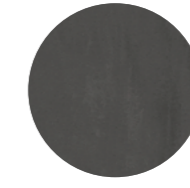

Carbon  
Concrete

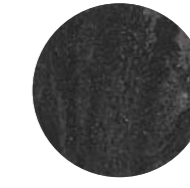

Cosmos  
Prima



# INFO

---

---

C01	<b>114</b>
C02	<b>116</b>
C03	<b>118</b>
C04	<b>120</b>
C05	<b>122</b>
C06	<b>124</b>

---

# 01

## COMPOSIZIONE M\_EMO

- Olmo Cenere  
Cenere Elm
- Laminam Orobico Grigio Opaco  
Laminam Orobico Grigio Matt

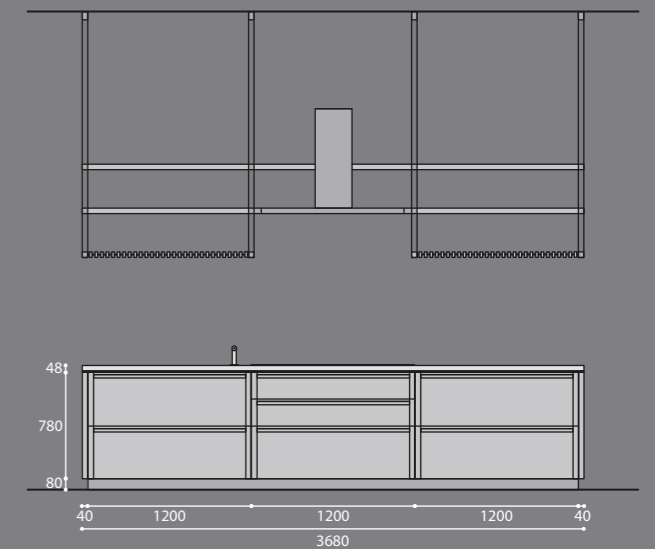
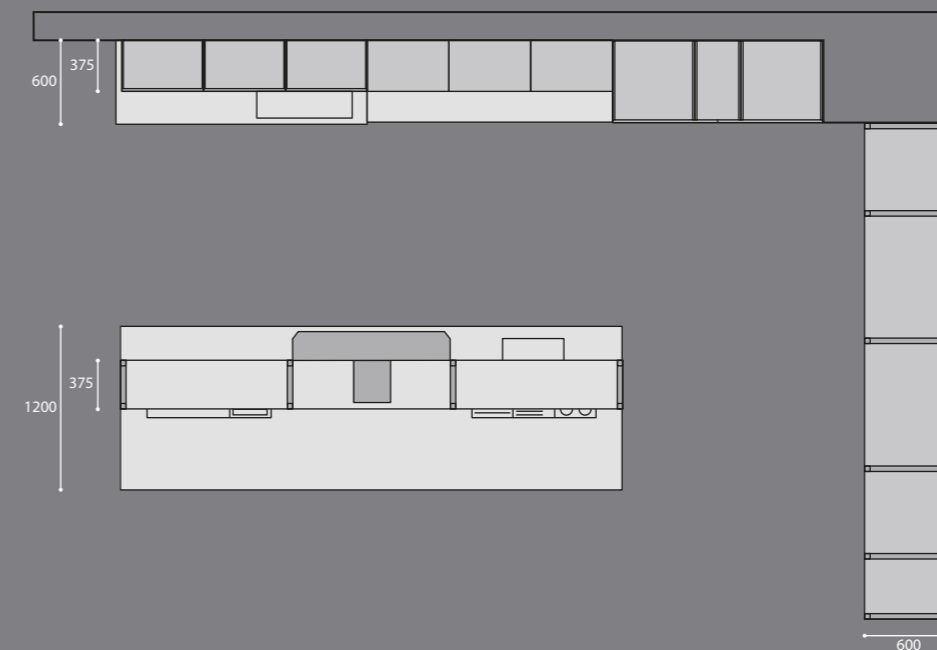
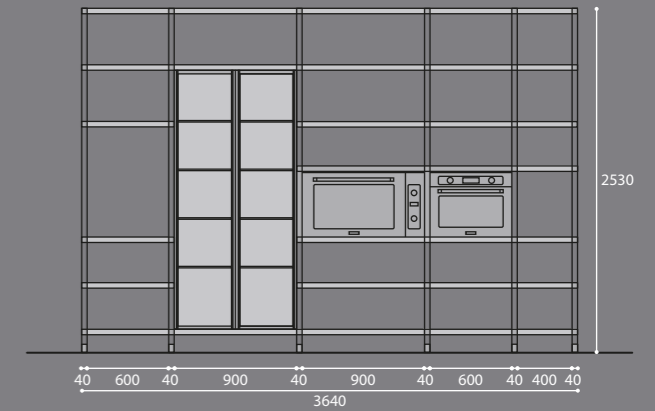
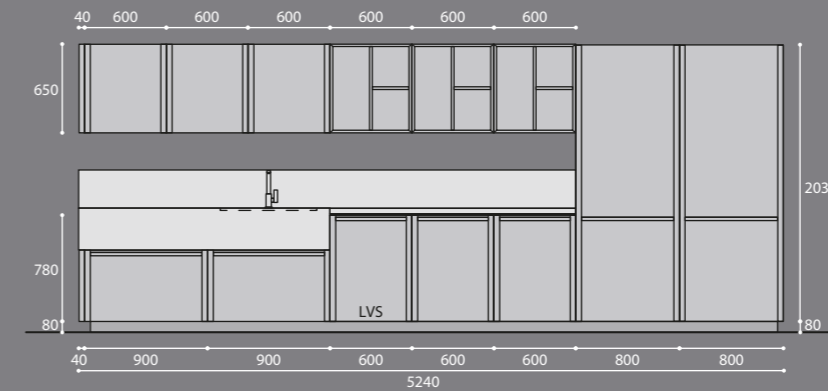
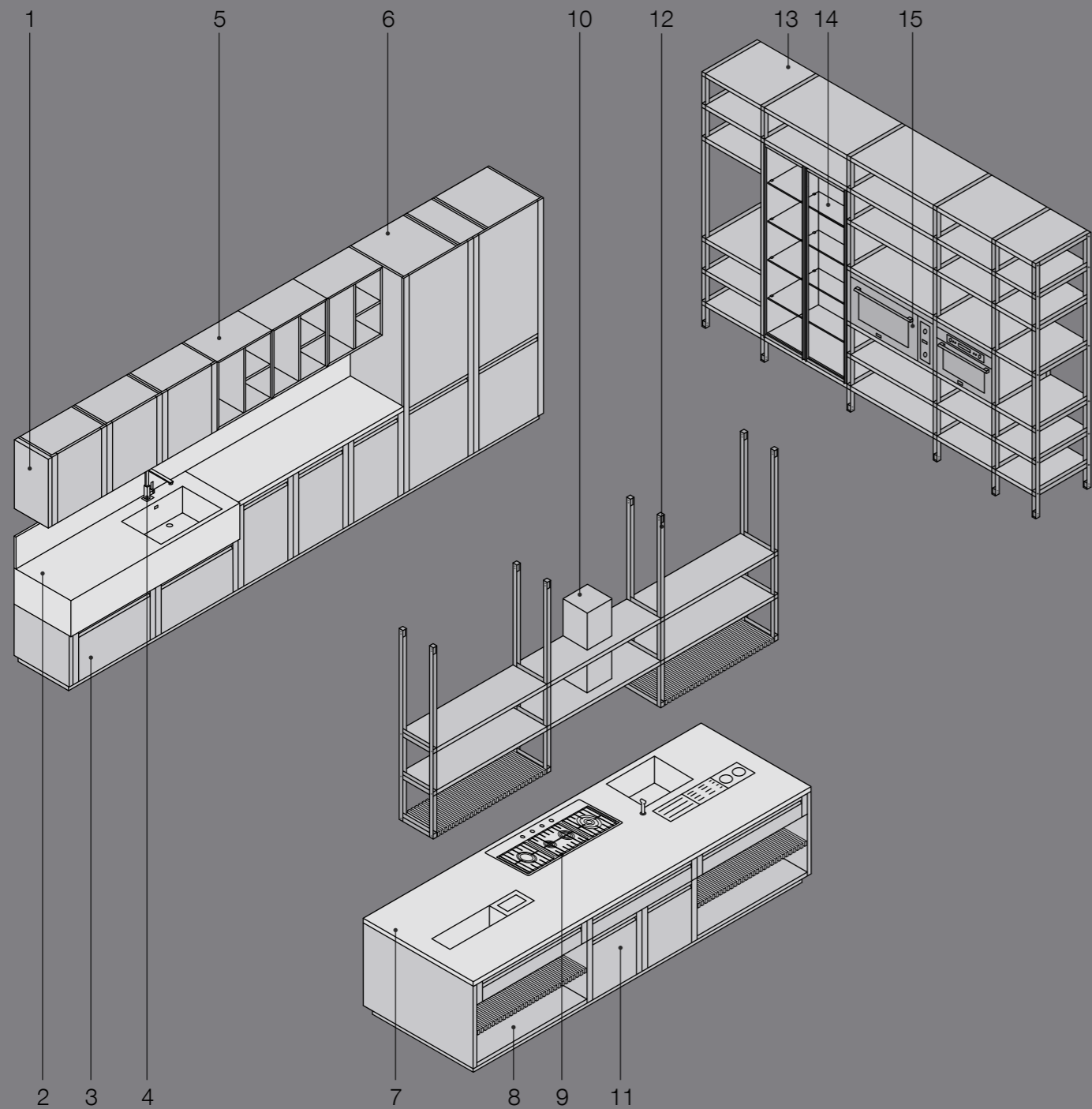

- |   |   |
|---|---|
| <ul style="list-style-type: none"> <li>01. Pensile h 650, frontale Olmo Cenere</li> <li>02. Piano di lavoro e rivestimento blocco lavello, Laminam Orobico Grigio Opaco</li> <li>03. Base, frontale Olmo Cenere e profilo Brown</li> <li>04. Rubinetto, Barazza</li> <li>05. Pensile folding a giorno h 650, Olmo Cenere con bordo laccato Brown</li> <li>06. Colonna h 2030, frontale Olmo Cenere e profilo Brown</li> <li>07. Piano di lavoro attrezzato, Laminam Orobico Grigio Opaco</li> <li>08. Base a giorno, Olmo Cenere e profilo Brown con rastrelliera in Olmo Cenere</li> </ul> | <ul style="list-style-type: none"> <li>09. Piano cottura, Kitchenaid</li> <li>10. Cappa Aliseo, Meson's</li> <li>11. Base, frontale Olmo Cenere e profilo Brown</li> <li>12. Struttura, montante Brown, ripiani e rastrelliera Olmo Cenere</li> <li>13. Struttura h 2530, montante Brown, ripiani Olmo Cenere</li> <li>14. Colonna vetro C_scrigno h 1900, Olmo Cenere, frontale telaio Brown e vetro trasparente</li> <li>15. Forni, Kitchenaid</li> </ul> |
|---|---|

- |  |  |
|--|--|
| <ul style="list-style-type: none"> <li>01. Wall unit h 650, Cenere Elm front</li> <li>02. Worktop and sink block coating, Laminam Orobico Grigio Matt</li> <li>03. Base unit, front in Cenere Elm and Brown profile</li> <li>04. Tap, Barazza</li> <li>05. Folding open wall unit h 650, Cenere Elm with Brown lacquered edge</li> <li>06. Tall unit h 2030, front in Cenere Elm and Brown profile</li> <li>07. Equipped worktop, Laminam Orobico Grigio Matt</li> <li>08. Open base unit, Cenere Elm and Brown profile with plate rack in Cenere Elm</li> </ul> | <ul style="list-style-type: none"> <li>09. Hob, Kitchenaid</li> <li>10. Aliseo hood, Meson's</li> <li>11. Base unit, front in Cenere Elm and Brown profile</li> <li>12. Structure, Brown upright, shelves and plate rack in Cenere Elm</li> <li>13. Structure h 2530, Brown upright, shelves in Cenere Elm</li> <li>14. C_scrigno glass tall unit h 1900, Cenere Elm, front with Brown frame and transparent glass</li> <li>15. Ovens, Kitchenaid</li> </ul> |
|--|--|



- Olmo Naturale  
Natural Elm
- Olmo Lava  
Lava Elm
- Laminam Pietra di Savoia Grigia Bocciardata  
Laminam Pietra di Savoia Grigia Bocciardata

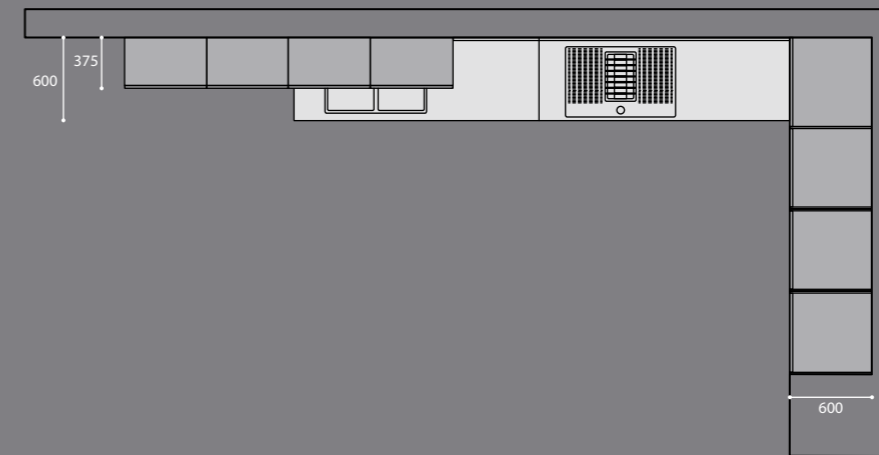
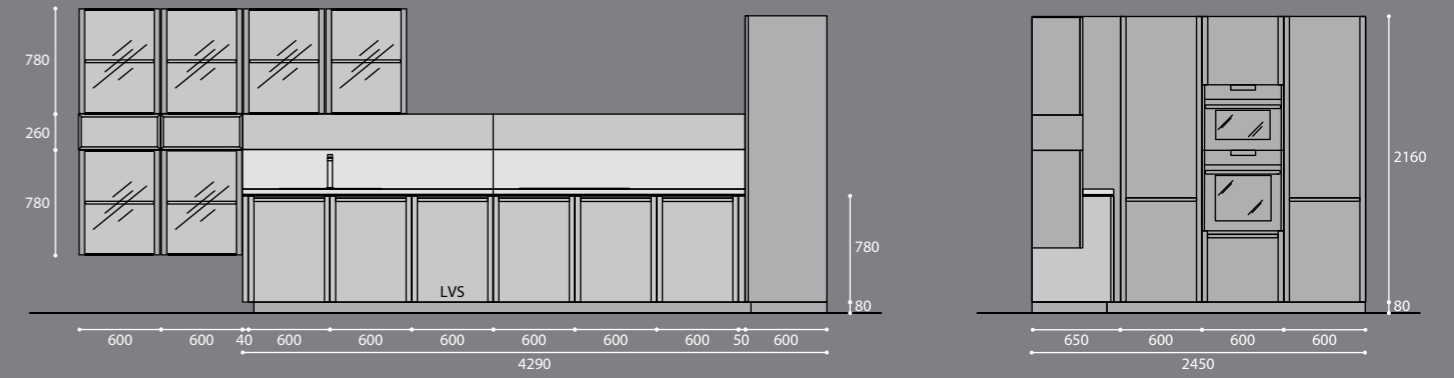
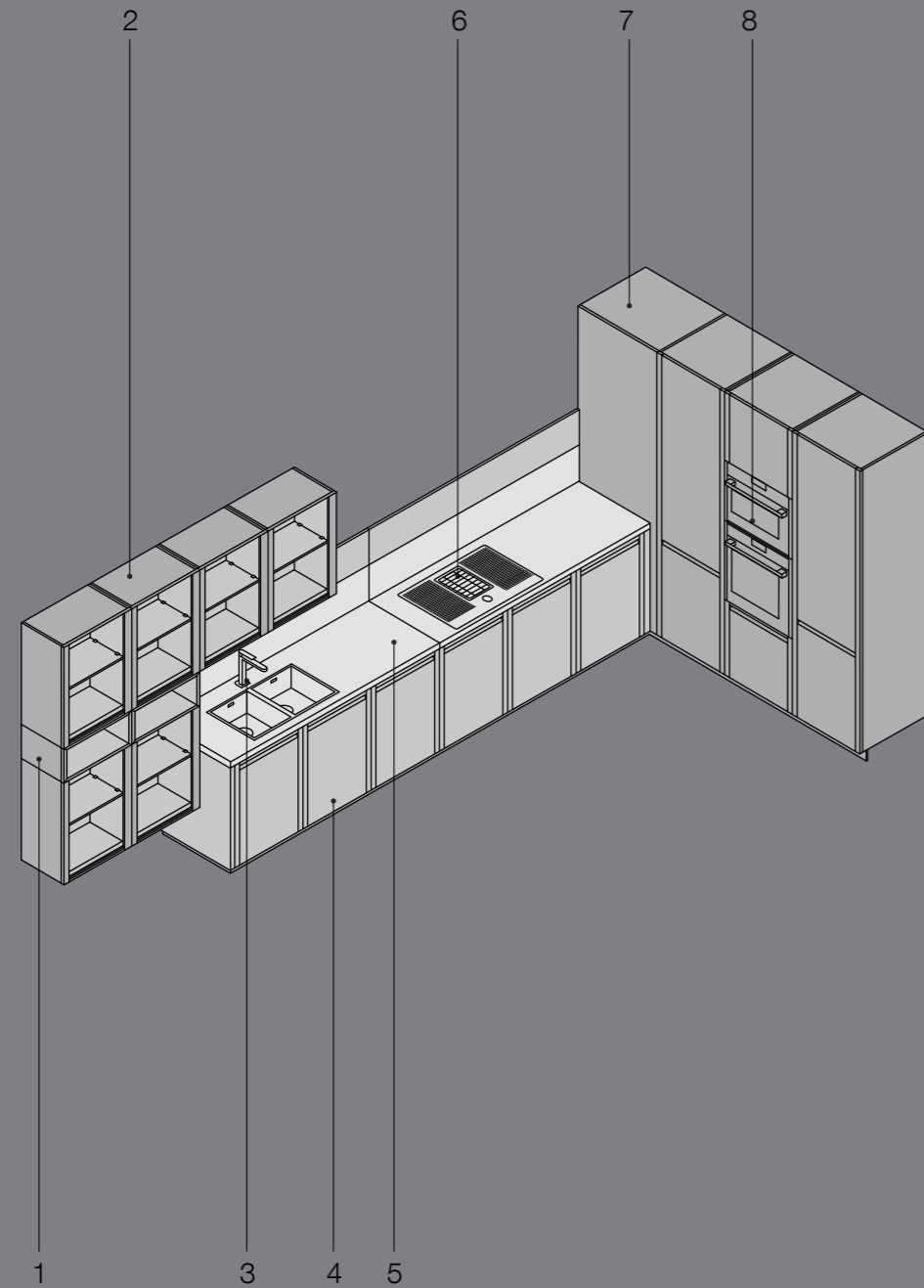

- 01. Pensile folding a giorno h 260, Olmo Naturale con bordo laccato Brown
- 02. Pensile C\_crystal h 780, Olmo Naturale, frontale telaio Brown e vetro flutes
- 03. Lavello, Foster  
Rubinetto, Fantini
- 04. Base, frontale Olmo Naturale e profilo Brown

- 05. Piano di lavoro, Laminam Pietra di Savoia Grigia bocciardata
- 06. Piano cottura con cappa integrata, Neff
- 07. Colonna h 2160, frontale Olmo Lava e profilo Brown
- 08. Forni, Neff

- 01. Folding open wall unit h 260, Natural Elm with Brown lacquered edge
- 02. C\_crystal h 780, Natural Elm, front with Brown frame and flutes glass
- 03. Sink, Foster  
Tap, Fantini
- 04. Base unit, front in Natural Elm and Brown profile

- 05. Worktop, Laminam Pietra di Savoia Grigia bocciardata
- 06. Hob with integrated hood, Neff
- 07. Tall unit h 2160, front in Lava Elm and Brown profile
- 08. Ovens, Neff

# 03

## COMPOSIZIONE M\_EMO

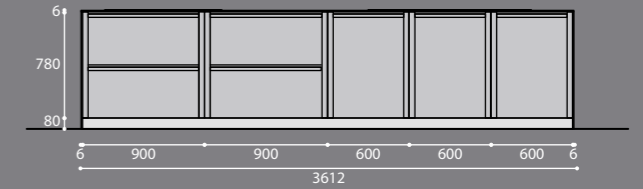
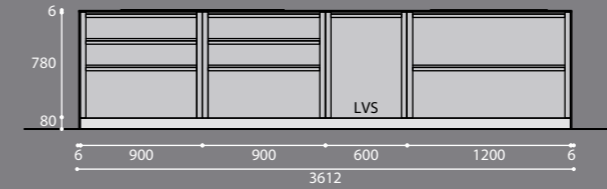
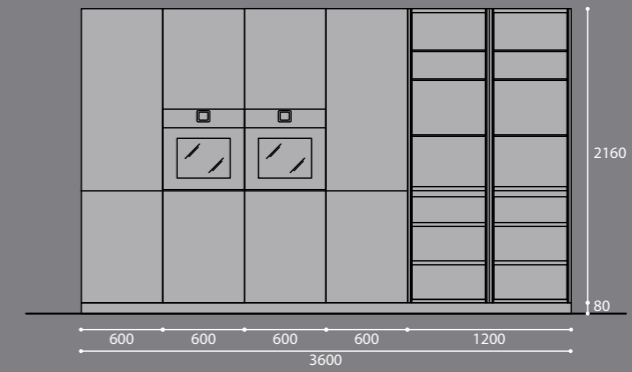
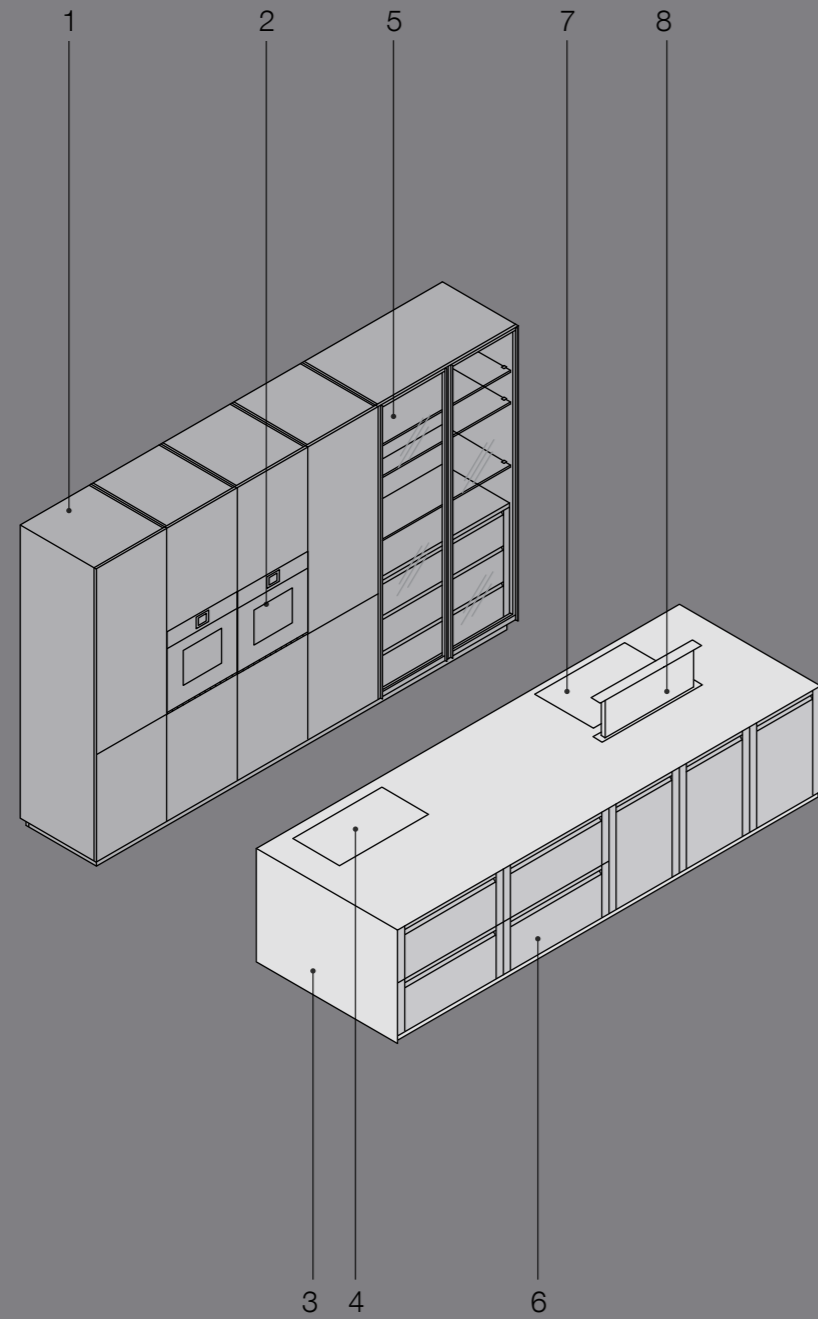
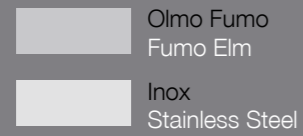

- 01. Colonna h 2160, frontale laccato Brown opaco
- 02. Forni, Barazza
- 03. Piano di lavoro e rivestimento fianco, Inox 6 mm
- 04. Lavello a scomparsa, Barazza
- 05. Colonna vetro C\_scrigno h 2160, frontale telaio Brown e vetro trasparente, accessoriata con tre cassetti e tre ripiani in vetro

- 06. Base, frontale Olmo Fumo e profilo Titanio
- 07. Piano cottura a scomparsa, Barazza
- 08. Cappa a scomparsa, Barazza

- 01. Tall unit h 2160, Brown matt lacquered front
- 02. Ovens, Barazza
- 03. Worktop and side panel coating, 6 mm Stainless steel
- 04. Concealed sink, Barazza
- 05. C\_scrigno glass tall unit h 2160, front with Brown frame and transparent glass, equipped with three drawers and three glass shelves

- 06. Base unit, front in Fumo Elm and Titanium profile
- 07. Concealed hob, Barazza
- 08. Concealed hood, Barazza



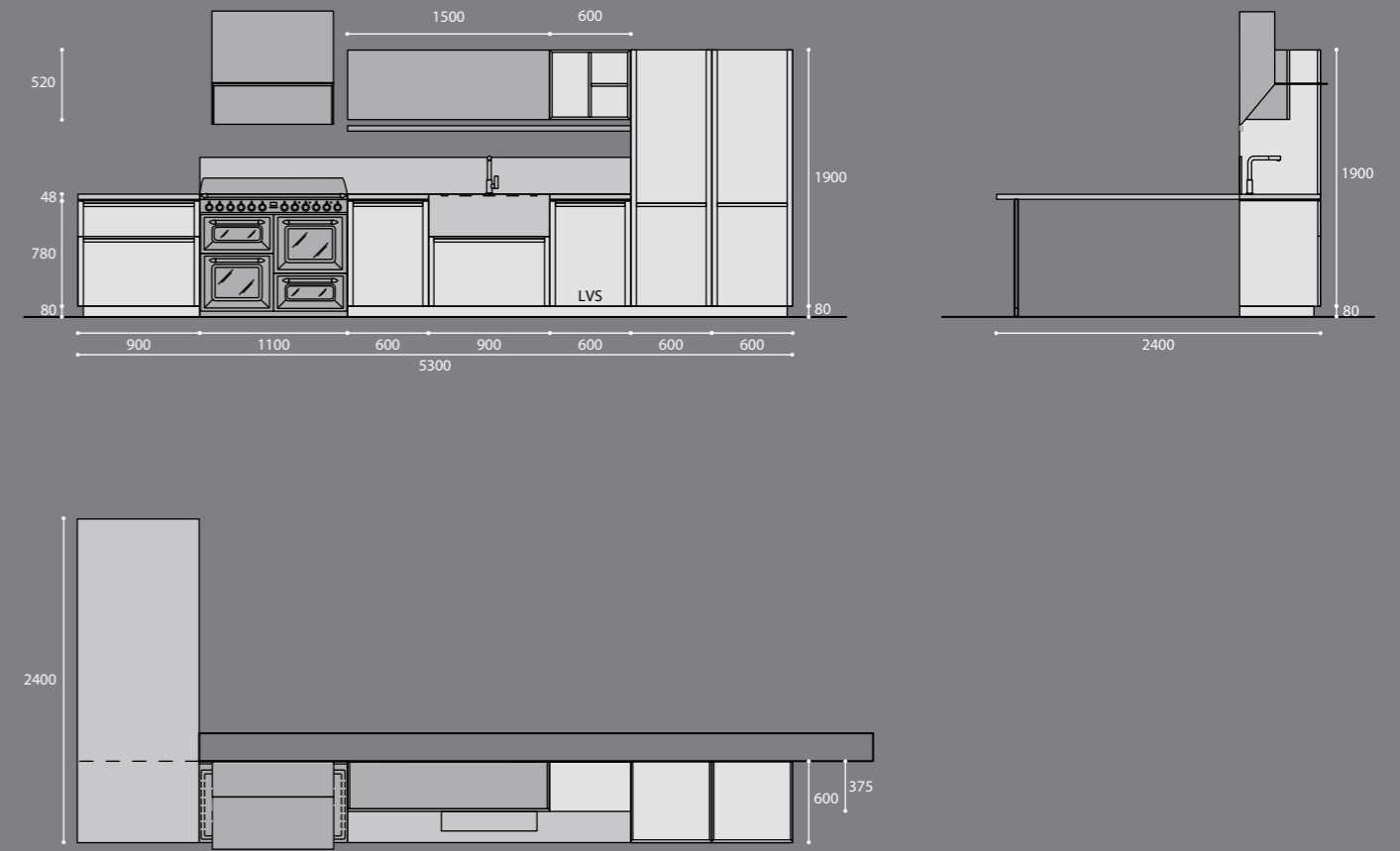
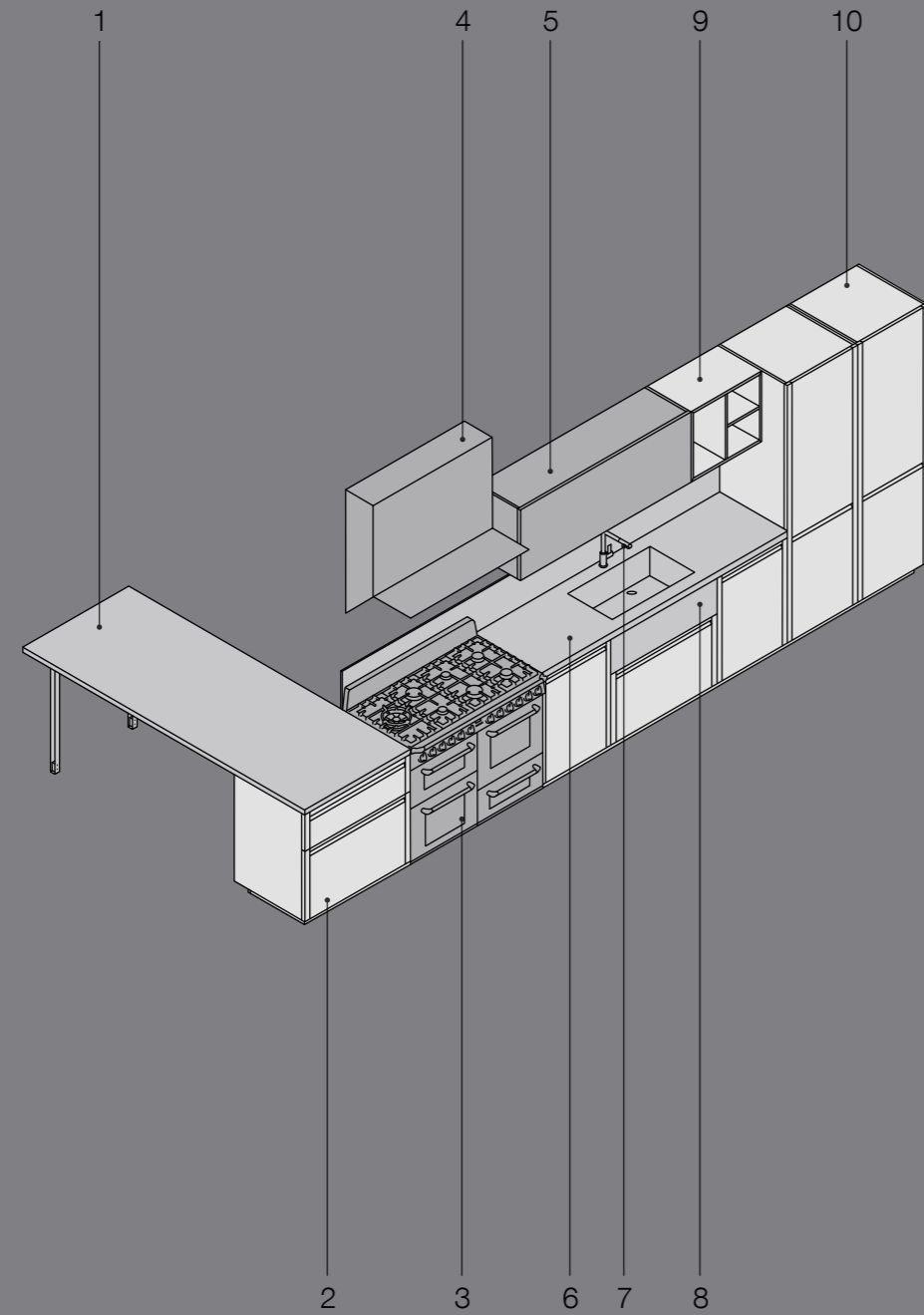

01. Piano penisola, Laminam Ossido Nero  
 02. Base, frontale Olmo Gesso e profilo Rame  
 03. Cucina, Smeg  
 04. Cappa parete Maestrале, Meson's  
 05. Pensile h 520, frontale laccato Brown opaco  
 06. Piano di lavoro, Laminam Ossido Nero  
 07. Rubinetto, Franke

08. Base, frontale fisso Laminam Ossido Nero,  
 frontale cestone Olmo Gesso  
 09. Pensile folding a giorno h 650, Olmo Gesso con  
 bordo laccato Brown  
 10. Colonna h 1900, frontale laccato Olmo e profilo  
 Rame

01. Peninsular unit top, Laminam Ossido Nero  
 02. Base unit, front in Gesso Elm and Rame profile  
 03. Cooker, Smeg  
 04. Maestrале wall-mounted hood, Meson's  
 05. Wall unit h 520, Brown matt lacquered front  
 06. Worktop, Laminam Ossido Nero  
 07. Tap, Franke

08. Base unit, fixed front in Laminam Ossido Nero,  
 deep drawer front in Gesso Elm  
 09. Folding open wall unit h 650, Gesso Elm with  
 Brown lacquered frame  
 10. Tall unit h 1900, Elm lacquered front and Rame  
 profile

- Olmo Tabacco  
Tabacco Elm
- Laminam Bianco Statuario Venato Soft Touch  
Laminam Bianco Statuario Venato Soft Touch

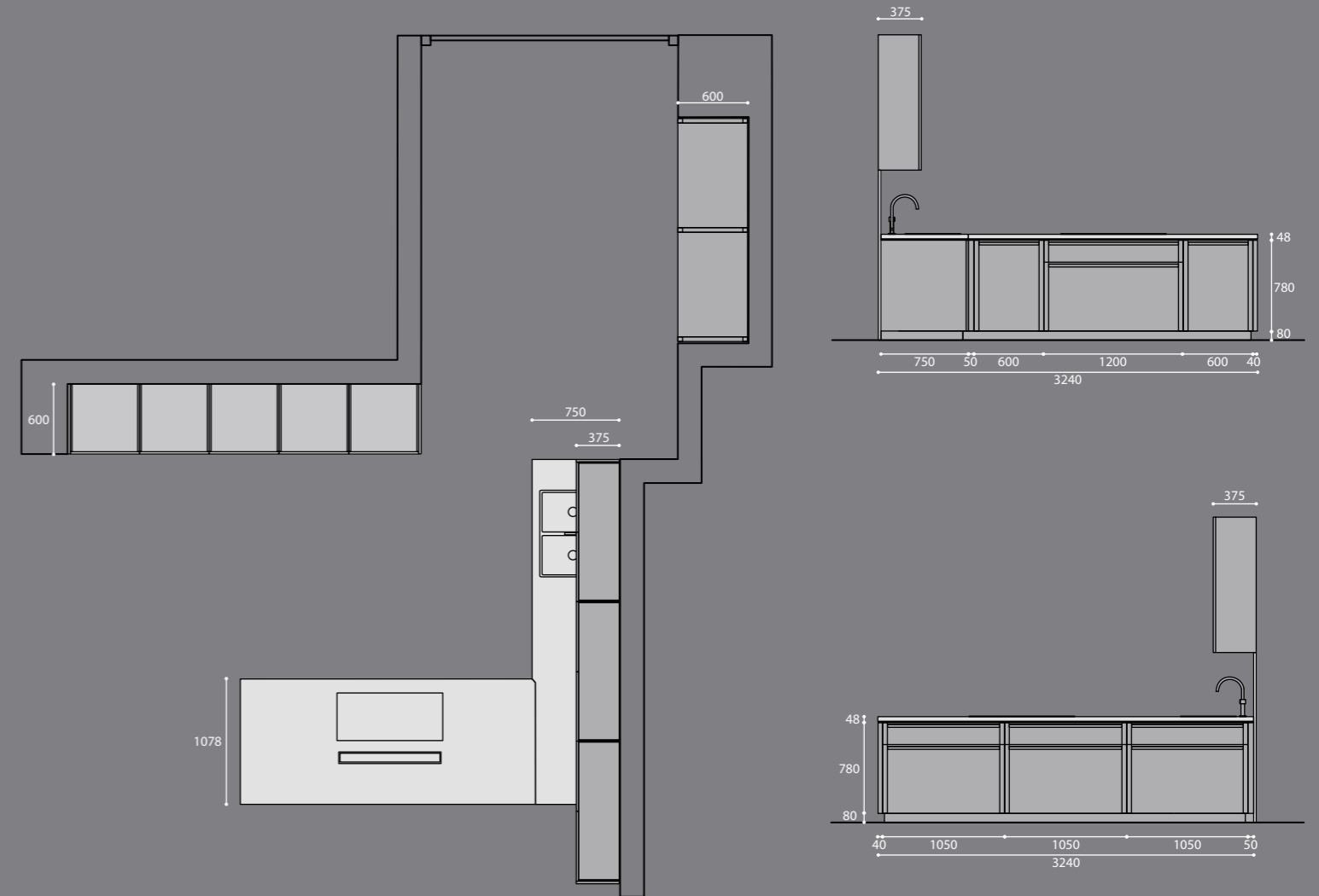
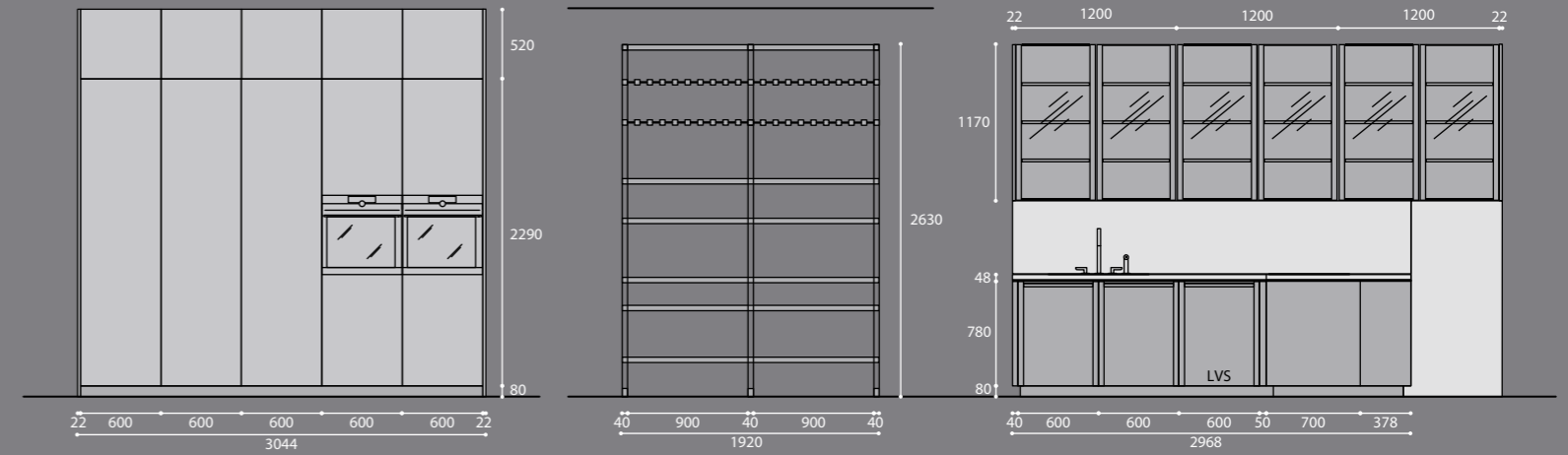
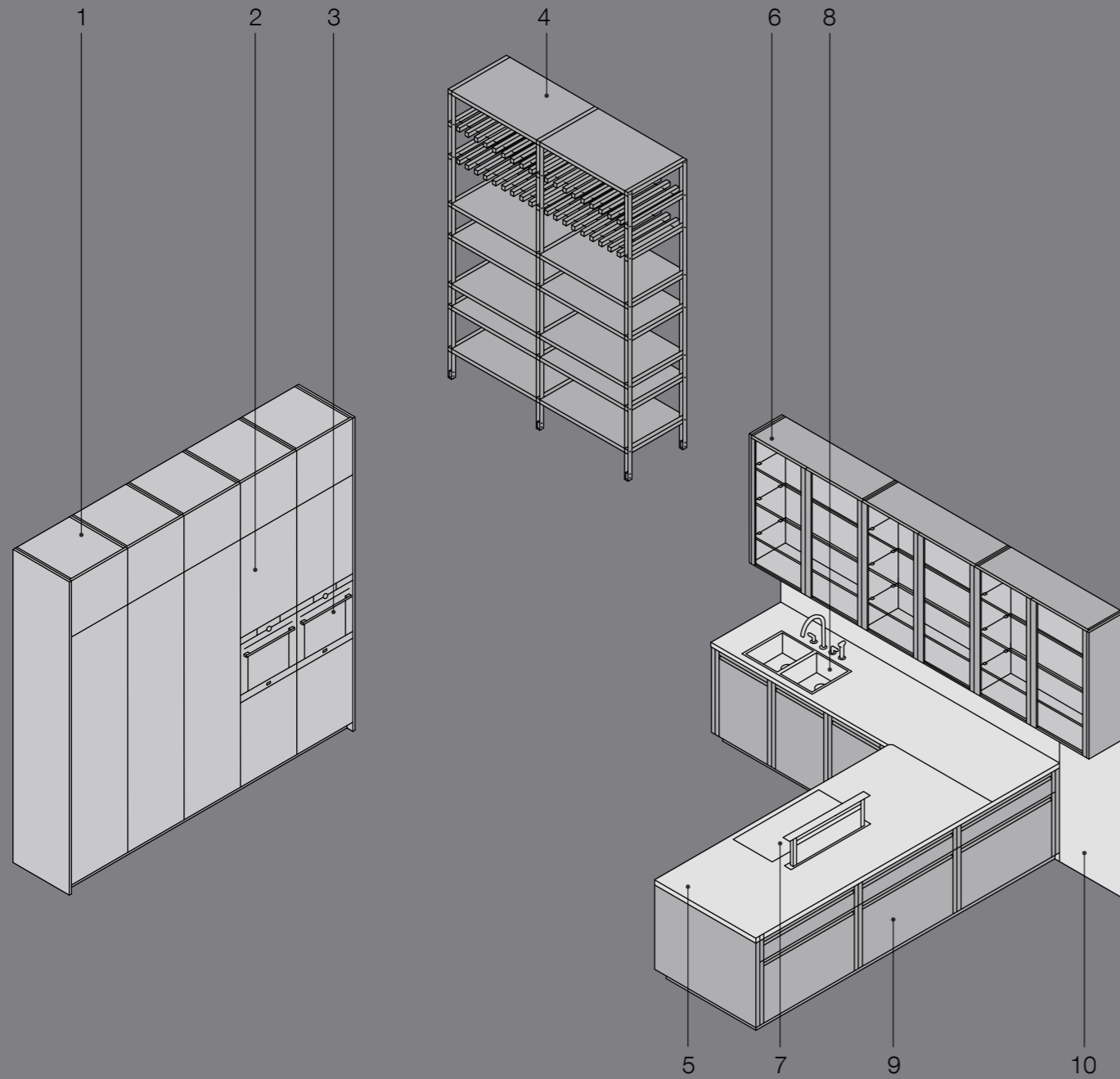

- 01. Colonna h 2290 con sopracolonna h 520, frontale laccato Burro lucido
- 02. Colonna frigo con apertura automatica
- 03. Forni, AEG
- 04. Struttura h 2630, montante Brown, ripiani e rastrelliera Olmo Tabacco
- 05. Piano di lavoro, Laminam Bianco Statuario Venato Soft Touch
- 06. Pensile C\_rystal h 1170, Olmo Tabacco, frontale telaio Brown e vetro trasparente
- 07. Piano cottura, AEG  
Cappa a scomparsa, AEG
- 08. Lavello, Franke  
Rubinetto, Fantini
- 09. Base, frontale Olmo Tabacco e profilo Titanio
- 10. Schienale, Laminam Bianco Statuario Venato Soft Touch

- 01. Tall unit h 2290 with tall unit top element h 520, Burro gloss lacquered front
- 02. Fridge Tall unit with automatic opening
- 03. Ovens, AEG
- 04. Structure h 2630, Brown upright, shelves and plate rack in Tabacco Elm
- 05. Worktop, Laminam Bianco Statuario Venato Soft Touch
- 06. C\_rystal wall unit h 1170, Tabacco Elm, front with Brown frame and transparent glass
- 07. Hob, AEG  
Concealed hood, AEG
- 08. Sink, Franke  
Tap, Fantini
- 09. Base unit, front in Tabacco Elm and Titanium profile
- 10. Back panel, Laminam Bianco Statuario Venato Soft Touch



- Olmo Naturale  
Natural Elm
- Laminam Nero Greco Opaco  
Laminam Nero Greco Matt

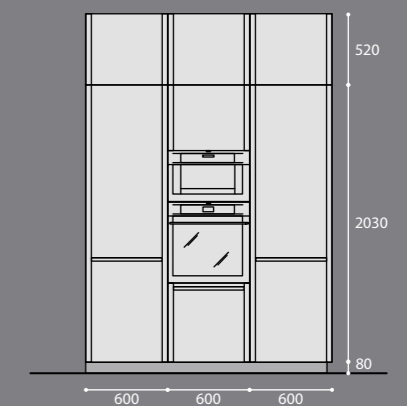
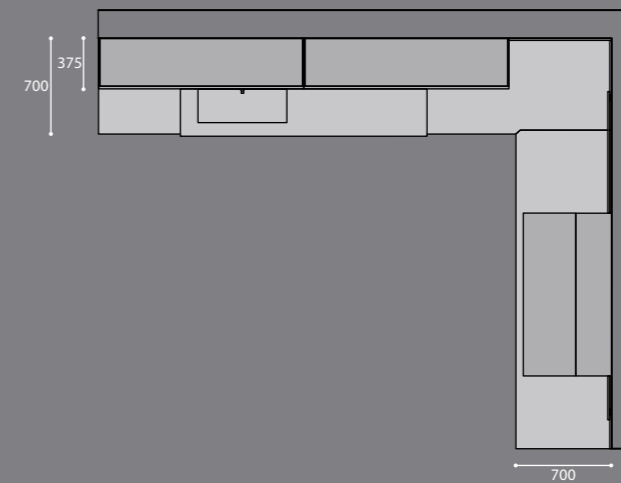
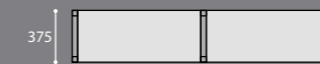
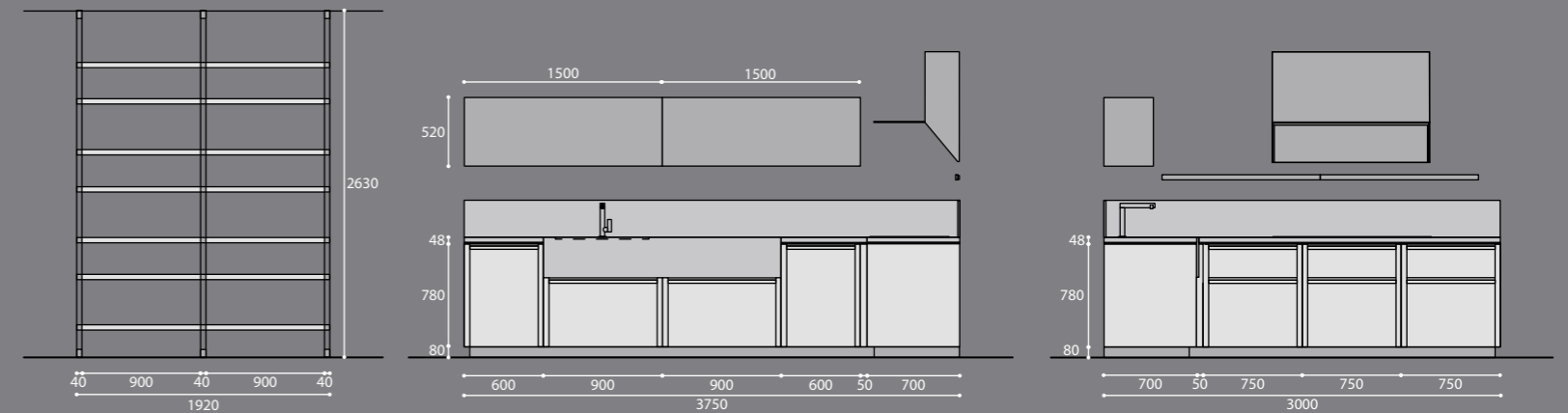
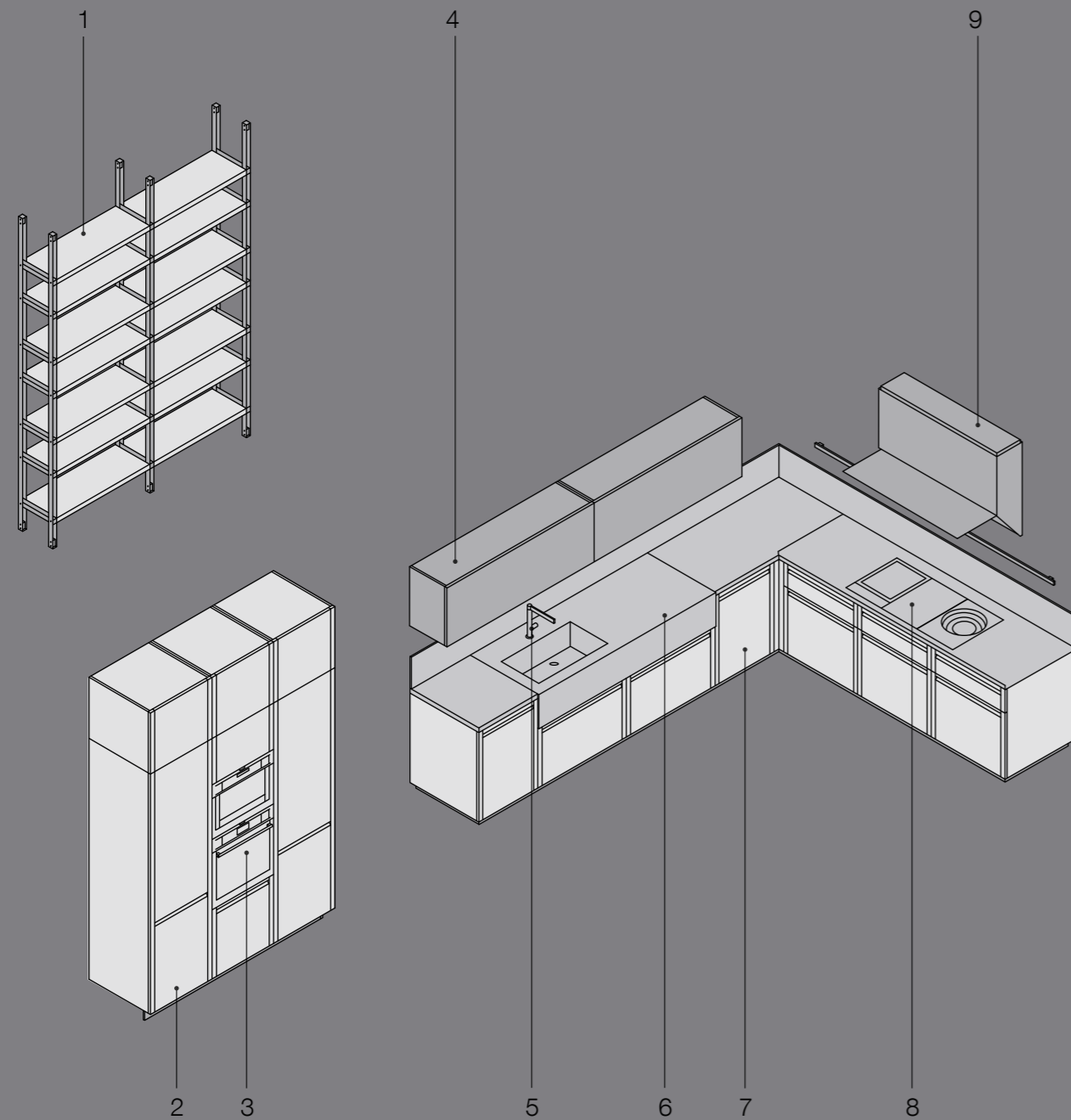

- 01. Struttura h 2630, montante Titanio, ripiani Olmo Naturale
- 02. Colonna h 2030 con sopracolonna h 520, frontale Olmo Naturale e profilo Brown
- 03. Forni, AEG
- 04. Pensile h 520, frontale laccato Ardesia lucido
- 05. Rubinetto, Franke

- 06. Piano di lavoro e rivestimento blocco lavello, Laminam Nero Greco opaco
- 07. Base, frontale Olmo Naturale e profilo Brown
- 08. Piano cottura, AEG
- 09. Cappa parete Maestrale, Meson's

- 01. Structure h 2630, Titanium upright, Natural Elm
- 02. shelves  
Tall unit h 2030 with tall unit top element h 520, front in
- 03. Natural Elm and Brown profile
- 04. Ovens, AEG
- 05. Wall unit h 520, Ardesia gloss lacquered front  
Tap, Franke

- 06. Worktop and sink block coating, Laminam Nero Greco matt
- 07. Base unit, Natural Elm front and Brown profile
- 08. Hob, AEG
- 09. Maestrale wall-mounted hood, Meson's





## CREDIT

**CONCEPT** MESON'S

**FOTO** FRANCO ZANUSSI

**FOTOREALISMO** TALEADESIGN.IT

**STYLIST** DORIS ANDREUTTI

**FOTOLITO** LUCEGROUP.IT

**GRAPHIC DESIGN** TALEADESIGN.IT

**TRADUZIONI** CHIARA PICCININ

**PRINT** LUCEGROUP.IT

OCTOBER 2017

Meson's si riserva la facoltà di apportare modifiche o migliorie in qualsiasi momento, anche senza preavviso. I campioni di colori e materiali hanno valore indicativo. Tutti i diritti sono riservati.

Meson's is entitled to make modifications and improvements at any time, even without notice. The colour and material samples have an indicative value. All rights are reserved.

# MESON'S

### Meson's Cucine srl

Via Gradisca, 1  
33087 Pasiانو di Pordenone  
Pordenone Italy  
T 0039 0434 614911  
F 0039 0434 628042  
www.mesons.it

### Servizio Clienti

T 0039 0434 614900  
F 0039 0434 628042  
studiomesons@mesons.it

### Servizio Utenti

T 0039 0434 614923  
F 0039 0434 628042

### International department

T 0039 0434 614972  
F 0039 0434 628042  
studiomesons@mesons.it

follow us on socials!



D00BC53

